

Technical Parameters

Model	BLA-6001
LEDs	SMD 3030 high power
LEDs	1pcs
CCT	W / WW/ CW
Dimension	43*32*7.5mm
Input Voltage	DC12V
Power Consumption	1.8W
Luminous Flux	100-120LM
Beam Angle	155°-160°
Ingress Protection	IP65
Cases	Anti-UV, Anti-static, flame retardant, ABS+Lens
Installation	3M adhesive tape / screws
Pixel Pitch	180mm*180mm
Connection	20pcs
Life Span	50,000H
Operating Temp	-20°C ~ +60°C

The tech-specification may be changed because of the technology improvement.

Connection

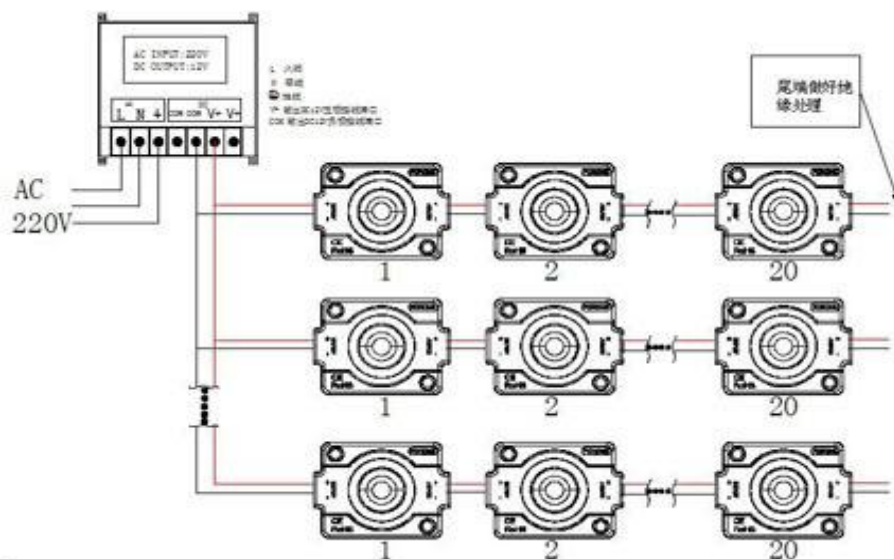

Application

Mainly used for lighting box, signage, and advertisement lighting.



Features:

Beam Angle : 155-160°

- Used for one face lighting box (Depth>10cm)
- Recommend distance between two modules : 180*180mm
- DC 12V input voltage , CVCC (constant voltage , constant current) design , more stable with longer life time
- Osram 3030 high power SMD . High brightness , good uniformity
- High efficiency ,low energy cost , save more cost and time on the installation

Dimension

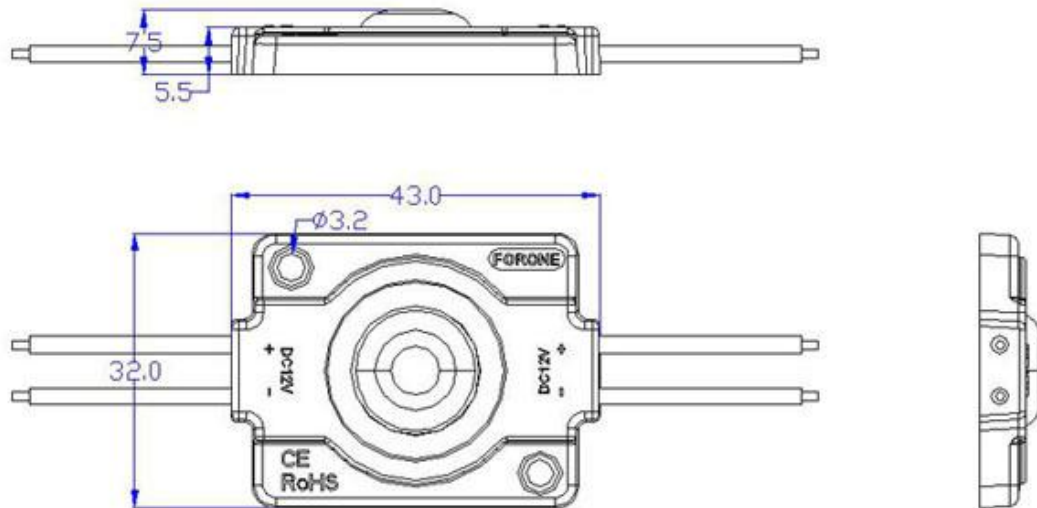

Notes:

1. Power wire should be $\leq 5m$
2. 20pcs modules per chain maximum
3. Please cut the module as the guide informed
4. Only work with thermal adhesive tape
5. Must be installed on the heat conduction material like : aluminum , iron, etc.

Usage

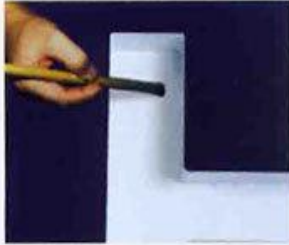

1, Clean the surface



2 put Two-face Adhesive on

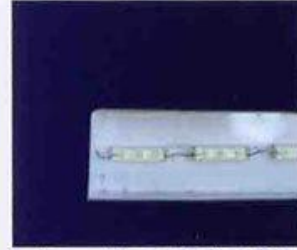

3, Arrange the modules in order



4, Fasten the module with bolt



5, Cut off the odds and fix wires

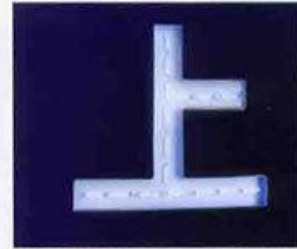

6, power with Switch Power Supply and test



Application



LED module used for lighting channel letter making:



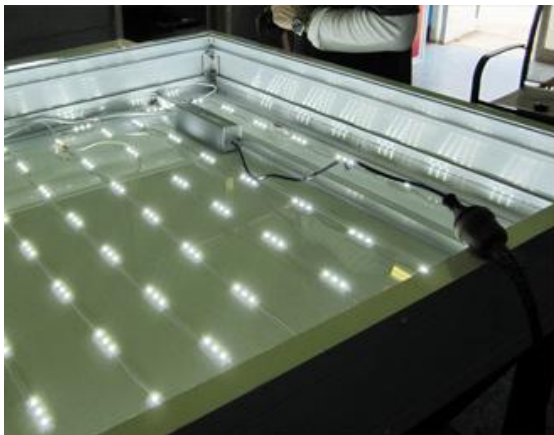



Process





product certification:
产品认证: CE FC ROSH