

Technical Parameters

Model	BLB-5402
LEDs	SMD 5730
Light Color	W/CW/WW
Beam Angle	120°
LED Qty	3pcs
Luminous Flux	160—180lm/PCS
CCT	W:6000~7000K,CW:9000~12000K,WW:2700~3300K
Input Voltage	DC12V
Power Consumption	1.44W
Drive Method	Constant Voltage
Connection	20pcs
Cases	ABS ; Flame retardant , anti-UV, anti-static
Dimension	70*15*7mm
Installation	Adhesive tape or M3 screw
Operating Temp	-40℃ ~ +60℃
Storage Temp.	-50℃ ~ +80℃
Ingress Protection	IP65

The tech-specification may be changed because of the technology improvement.

Connection

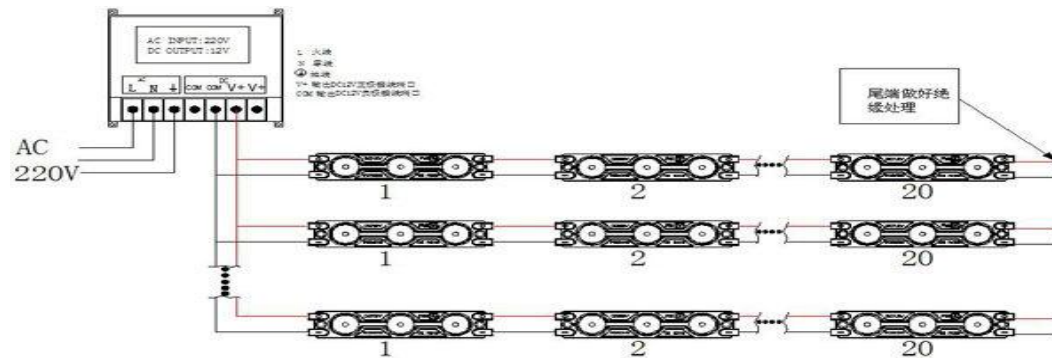

Application

Backlighting of light boxes (Depth: 80-200mm)

Backlighting of letters (Depth: 80-200mm)

Signage and illuminated advertising (Depth: 80-200mm)



Features:

- One BLB-5402 plus module chain comprises 20pcs individual modules
- Lens series make wider viewing angle with perfect uniformity
- Two LEDs per module
- Ingress protection IP65
- Pre-mounted adhesive tape allows easy mounting
- 12V DC power supply
- Integrated heat sink solution with aluminum PCB.
- Lighting colors: W/RGB/Y for optional
- Original LG ABS cases material

- Dimension (unit: mm):

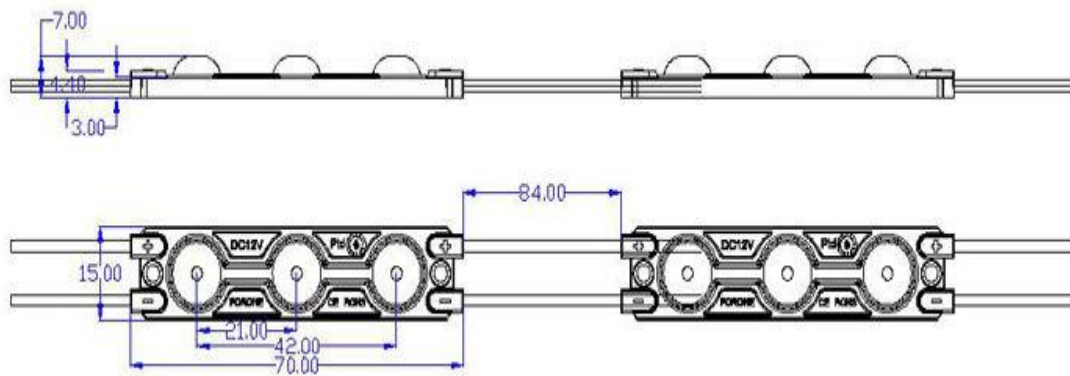

- Notes:

1. Power wire should be $\leq 5m$.
2. 20pcs modules per chain maximum.

Usage

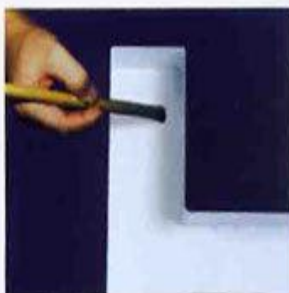

1, Clean the surface



2 put Two-face Adhesive on



3, Arrange the modules in order



4, Fasten the module with bolt



5, Cut off the odds and fix wires

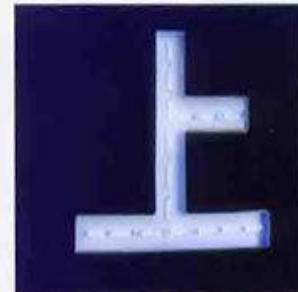

6, power with Switch Power Supply and test



Application



LED module used for lighting channel letter making:



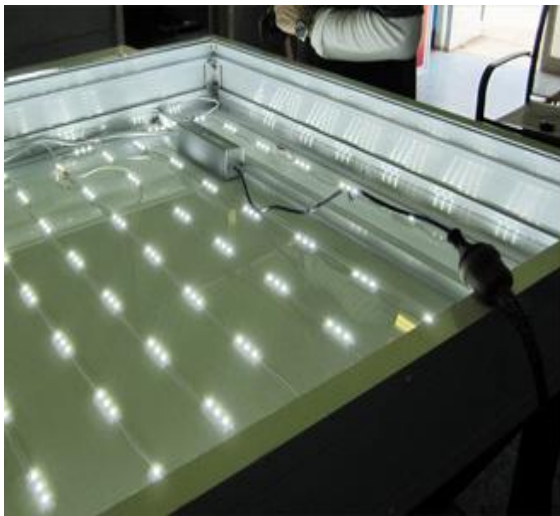



Process





product certification:

产品认证：CE FC ROHS