

Technical Parameters

| | |
|--------------------|---|
| Model | BLC-5002 |
| LEDs | 3528 SMD LED |
| Light Color | R/G/B/Y/W/CW/WW |
| Beam Angle | 120° |
| LED Qty | 3pcs |
| Luminous Flux | W/CW/WW: 18-24lm |
| CCT | W: 6000~7000K CW:9000-12000k WW: 2700~3300K |
| Life Span | 50,000h |
| Input Voltage | DC12V |
| Power Consumption | 0.3W/module |
| Drive model | Constant voltage |
| Cases | Anti- static,flame retardant , ABS+anti-UV |
| Dimension | 44*11*5.3mm |
| Ingress Protection | IP65 |
| Connection | 20pcs/chain |
| Operating Temp | -30℃ ~ +60℃ |
| Storage Temp. | -40℃ ~ +80℃ |

The tech-specification may be changed because of the technology improvement.

Connection

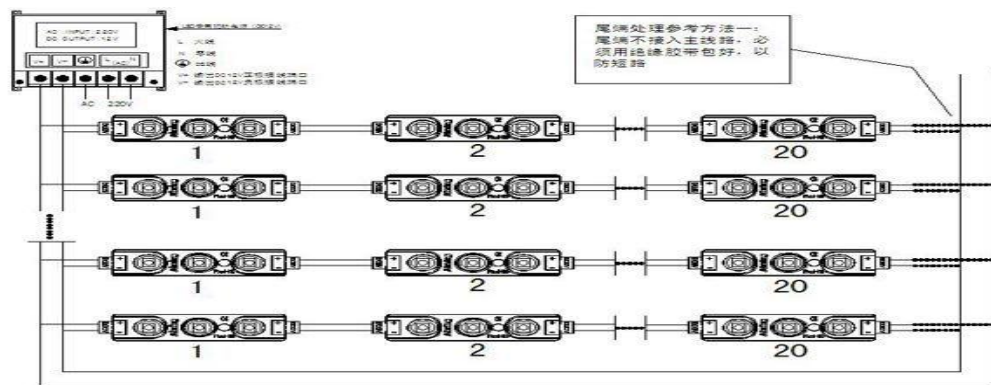

Application

Backlighting of light boxes (Depth: 50-120mm)

Backlighting of letters (Depth: 50-120mm)

Signage and illuminated advertising (Depth: 50-120mm)



Features:

- One BLC-5002 plus module chain comprises 20pcs individual modules
- Three LEDs per module
- Ingress protection IP65
- Pre-mounted adhesive tape allows easy mounting
- 12V DC power supply
- Integrated heat sink solution
- Lighting colors: W/RGB/Y for optional
- Original LG ABS cases material

- Dimension (unit: mm):

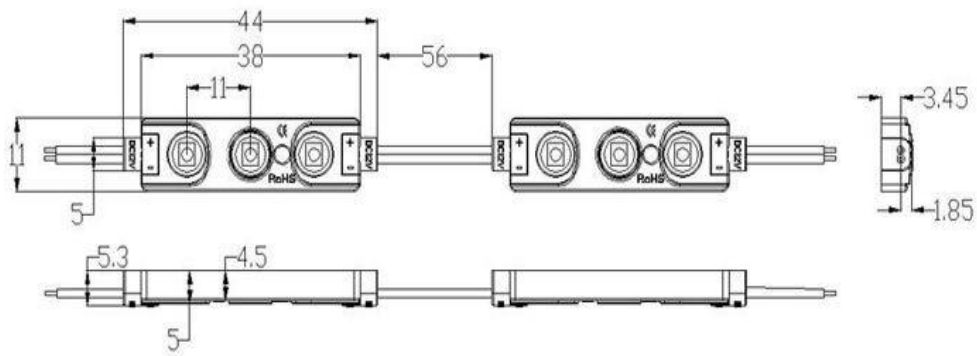

- Notes:

1. Power wire should be $\leq 5m$.
2. 20pcs modules per chain maximum.

Usage

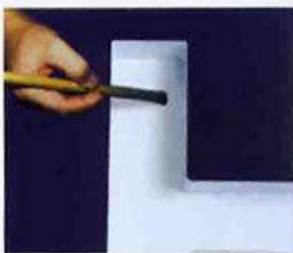

1, Clean the surface



2 put Two-face Adhelsive on

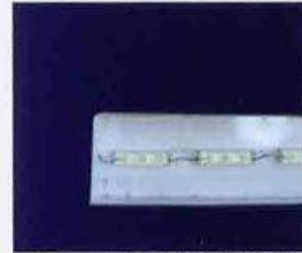

3, Arrange the modules in order



4, Fasten the module with bolt



5, Cut off the odds and fix wires

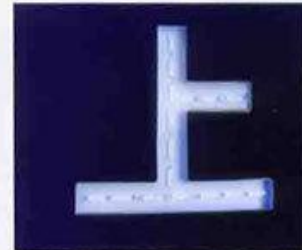

6, power with Switch Power Supply and test



Application



LED module used for lighting channel letter making:



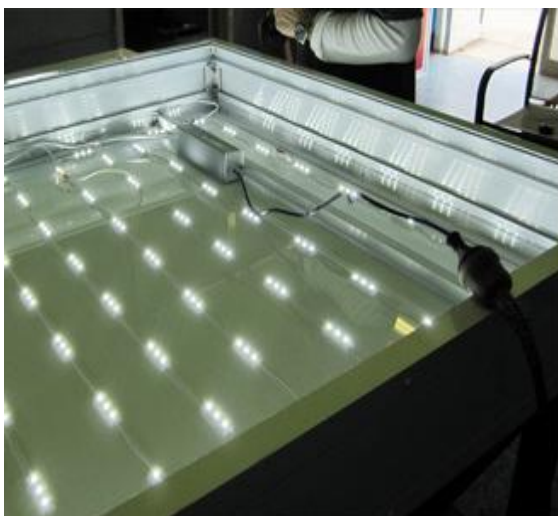



Process





product certification:
产品认证：CE FC ROSH